

Triple H40 Standard Features

TRAVEL		AUTOMATIC TOOL CHANGER	
X, Y, Z axes	510x510x400 mm [20.1"x20.1"x15.7"] (OP. X axis 700 mm [27.6"])	Max. tool diameter (Adjacent pots full / empty)	Dia. 90 / 180 mm [Dia. 3.5" / 7.1"]
Spindle center to Pallet surface	310-820 mm [12.2"-32.3"]	Max. tool length	300 mm [11.8"]
Spindle nose to Pallet center	70-470 mm [2.8"-18.5"]	Max. tool weight	8 kgs [17.6 lbs]
Pallet top height (from floor)	805 mm [31.7"]	Tool selection system	Fixed Tool Pot
PALLET		Chip to Chip	4.5 sec. with min. index, 5.5 sec. with max. index
Pallet size	820x450 mm [32.3"x17.7"]	MOTOR	
Max. work height	790 mm [31.1"]	Spindle motor (15 min/cont)	18.5 / 15 kW [25 / 20 HP]
Max. load	1,000 kgs [2,200 lbs]	Feed axis motors (X/Y/Z)	3.0 / 7.0 / 3.0 kW [4.0 / 9.4 / 4.0 HP]
Configuration	Three T-Slots of 18 mm [0.7"] P=125 mm [4.9"]	Lubrication pump motor	Grease: 20W [0.027 HP]
SPINDLE		Coolant pumps	600 W [0.8 HP] x 3
Spindle speed	8,000 min ⁻¹ (OP. 12,000 min ⁻¹)	Hydraulic pump (OP. for fixtures)	2.2 kW [3.0 HP]
Max. torque	118 Nm (15 min.)	SUPPLY	
Spindle taper	7/24 Taper No. 40	Electric voltage	200 V 50/60 Hz
FEED		Electric power supply	36 kVA
Rapid feed	60,000 mm/min. [2,362 ipm]	Air pressure	0.4 MPa [58 psi]
Cutting feed	30,000 mm/min. [1,181 ipm]	Air volume	360 liters/min. [95 gal/min.]
Acceleration (X/Y/Z)	0.4 / 1.3 / 0.5 G	TANK	
AUTOMATIC TOOL CHANGER		Coolant tank	450 liters [119 gal.]
Type of tool shank	BT40 / CAT40	SIZE	
Type of pull-stud	JIS	Floor space	1,400x3,150 mm [55.1"x124.0"]
Number of tools	20 (OP. 40 / 60 / 80) Note: 60 / 80 uses ATC arm.	Machine height	2,617 mm [103.0"] (with 20ATC)
		Machine weight	5,700 kg [12,600 lbs]

- Machine Options**
- Through spindle coolant system 1.5/4.0/7.0/15.0 MPa [220/580/1000/2200 psi]
 - Spindle jacket cooling system
 - Program end signal light
 - Outside chip conveyor
 - Weekly timer
 - Automatic power off
 - Machine color
 - Interface for safety measures
 - Hybrid guide

FANUC 0i-MF (Package 1) ● Standard Features □ Options

- | | | |
|--|--|--|
| <ul style="list-style-type: none"> ● Controlled axes: 3 (OP. Max. 5) ● Max. simultaneously controlled axes: 3 (OP. Max. 4) ● Spindle override 50-150% (each 10%) ● Cutting feed override 0-200% (each 10%) ● Rapid traverse override 1,2,4,8,15,25,50,100% ● Rapid traverse bell-shaped acceleration/deceleration ● Manual handle feed 1 unit ● Thread cutting, synchronous cutting ● Workpiece coordinate system ● Addition of workpiece coordinate system 48 sets ● Programmable data input G10 | <ul style="list-style-type: none"> ● Custom macro ● Canned cycles for drilling ● Scaling ● Rigid tapping ● Tool offset: 400 pcs ● Tool radius / Tool nose radius compensation ● Stored pitch error compensation ● Part program storage: 512 Kbyte ● Number of registrable programs: 400 pcs ● Background editing ● Run hour and parts count display ● Single direction positioning | <ul style="list-style-type: none"> ● Cylindrical interpolation ● Helical interpolation ● AI advanced preview control (20 look-ahead blocks) ● Optional chamfering / corner R ● Automatic corner override ● Programmable mirror image ● Coordinate system rotation ● Tool offset memory C ● Tool life management <input type="checkbox"/> AI contour control (40 look-ahead blocks) <input type="checkbox"/> AI contour control II (200 look-ahead blocks) <input type="checkbox"/> Optional block skip |
|--|--|--|

MACHINE SIZE

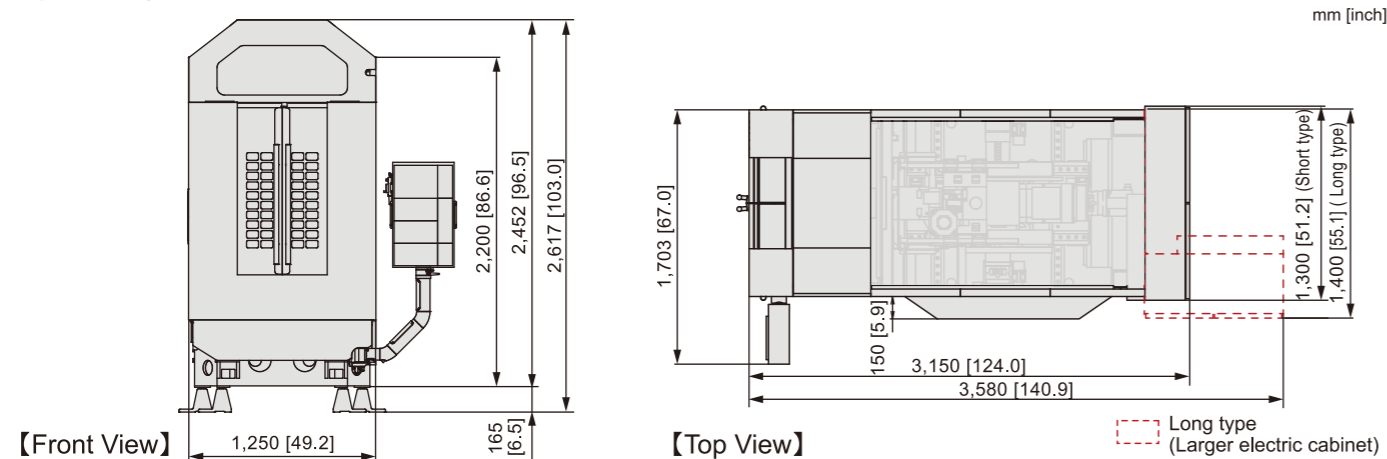

Specifications and dimensions are subject to change without notice.

(The machine on the front cover includes automatic door, signal light and other optional features.)

KIWA MACHINERY CO., LTD.

522-51 Harade Kuramochi-cho,
Nabari, MIE 518-0752, JAPAN
TEL : 0595-64-4758 FAX : 0595-64-7529
WEB : <http://www.kiwa-mc.co.jp/en/>
E-mail : overseas@kiwa-mc.co.jp

2015.10E

KIWA Japan

Triple H40

Column Traverse Type Horizontal Machining Center



KIWA MACHINERY CO., LTD.

Here comes a New Horizontal Machining Center with Column Traverse Structure

ATC without Tool Change Arm
Magazine Capacity: 20 tools
(OP. 40 tools)

Long-nosed Spindle with Rigidity

Flexible Mounting of Various Fixtures and Rotary Tables According to Application

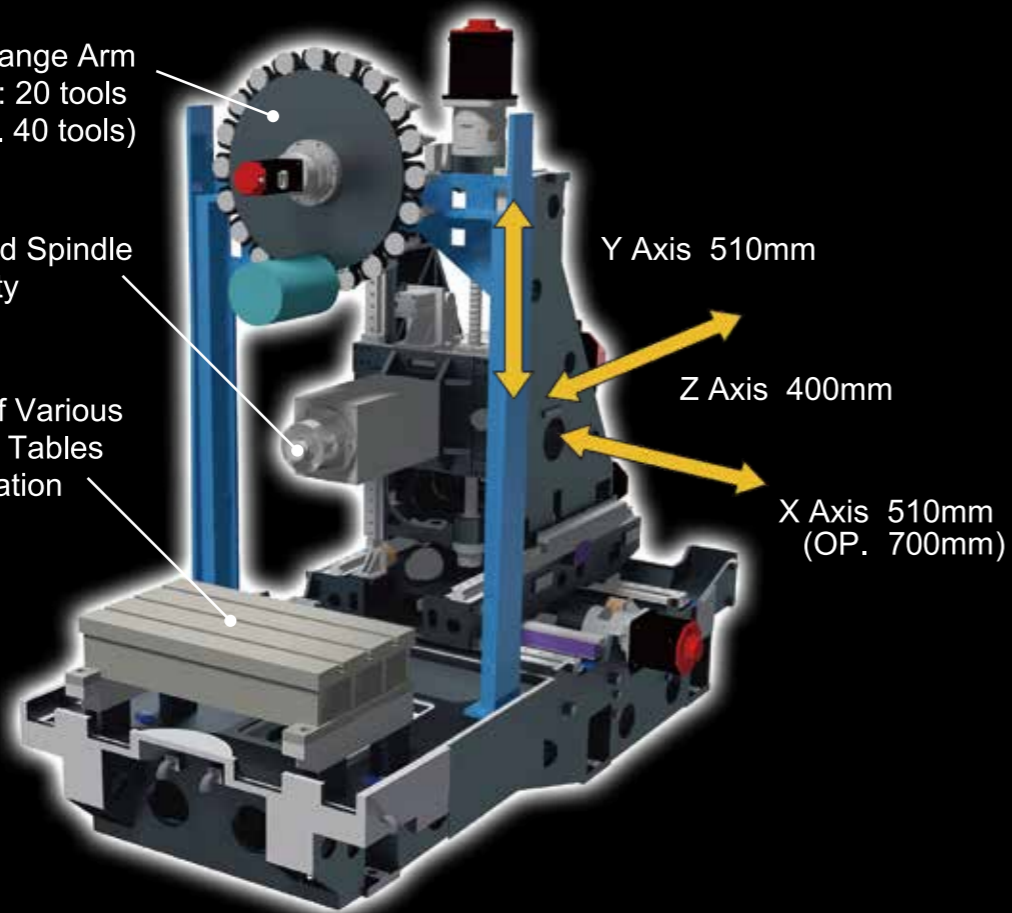

High Reliability

Trouble-free design

Armless ATC (20-/40-tool system)

Tool change does not rely on a tool change arm. Instead, the spindle directly changes tools with the magazine.

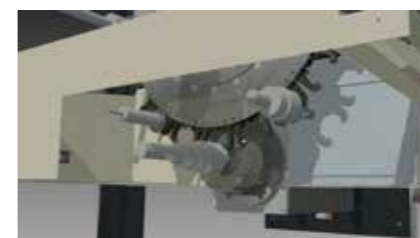

Isolation of Machining Area from Mechanism

By separating the machining area from the axis driving mechanism by the vertical slide covers, troubles of the driving components caused by coolant and chips are substantially reduced.



Smooth Chip Disposal

Thanks to the column moving structure, the volume of the machining area is minimized. Combined with the large opening in the bed, very efficient chip disposal is possible.

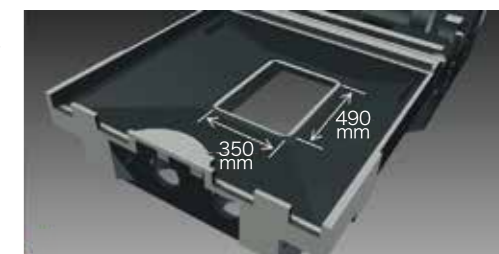

User-Friendliness

Adaptable to a Variety of Applications

Because of the fixed table structure, piping arrangement for automatic clamping fixtures is easy, and the mounting height of work pieces is freely adjustable depending on customers' requirements. It is also possible to install various types of rotary tables.



Space Saving / Energy Saving

The compact body is the most suitable for machining lines. The standard machine has no hydraulic unit, contributing to power saving.



High Rigidity Easily cuts ferrous materials

Rigid Spindle with Power

The Z-axis moves with back and forth movements of the column. That assures higher rigidity of the spindle than quill type spindles. The spindle unit has 6 bearings for better stability.

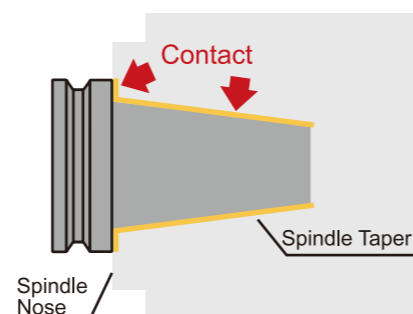
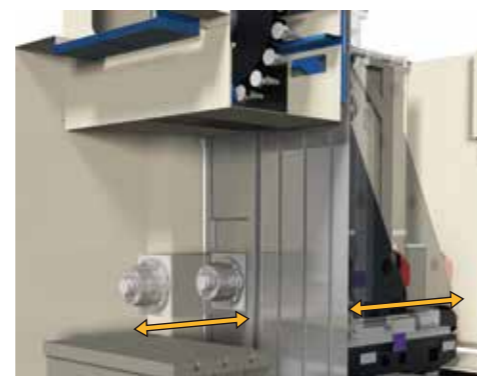
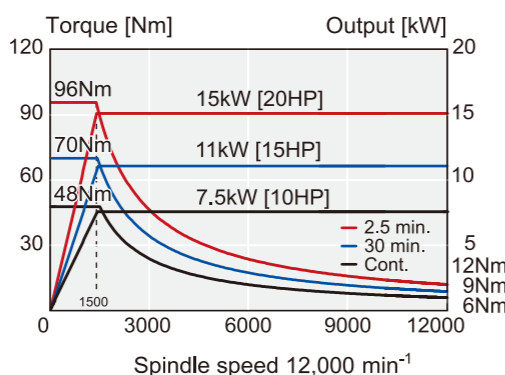
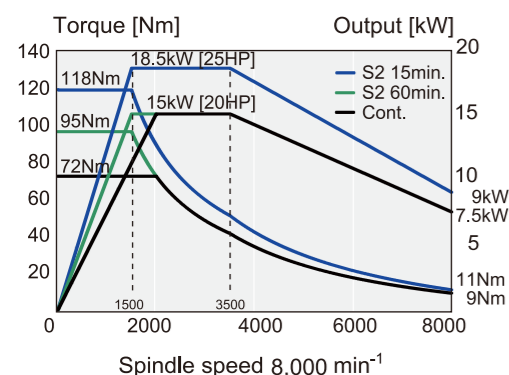

Double Contact
The spindle is designed to accept double contact tool holders.

Flexibility in Material Handling

By construction of wide-ranging peripheral equipment such as robots and gantry loaders, automated machining can be realized.

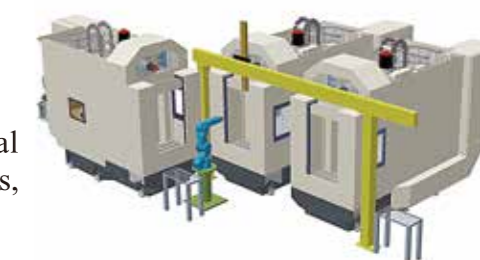

Here comes a New Horizontal Machining Center with Column Traverse Structure

ATC without Tool Change Arm
Magazine Capacity: 20 tools
(OP. 40 tools)

Long-nosed Spindle with Rigidity

Flexible Mounting of Various Fixtures and Rotary Tables According to Application

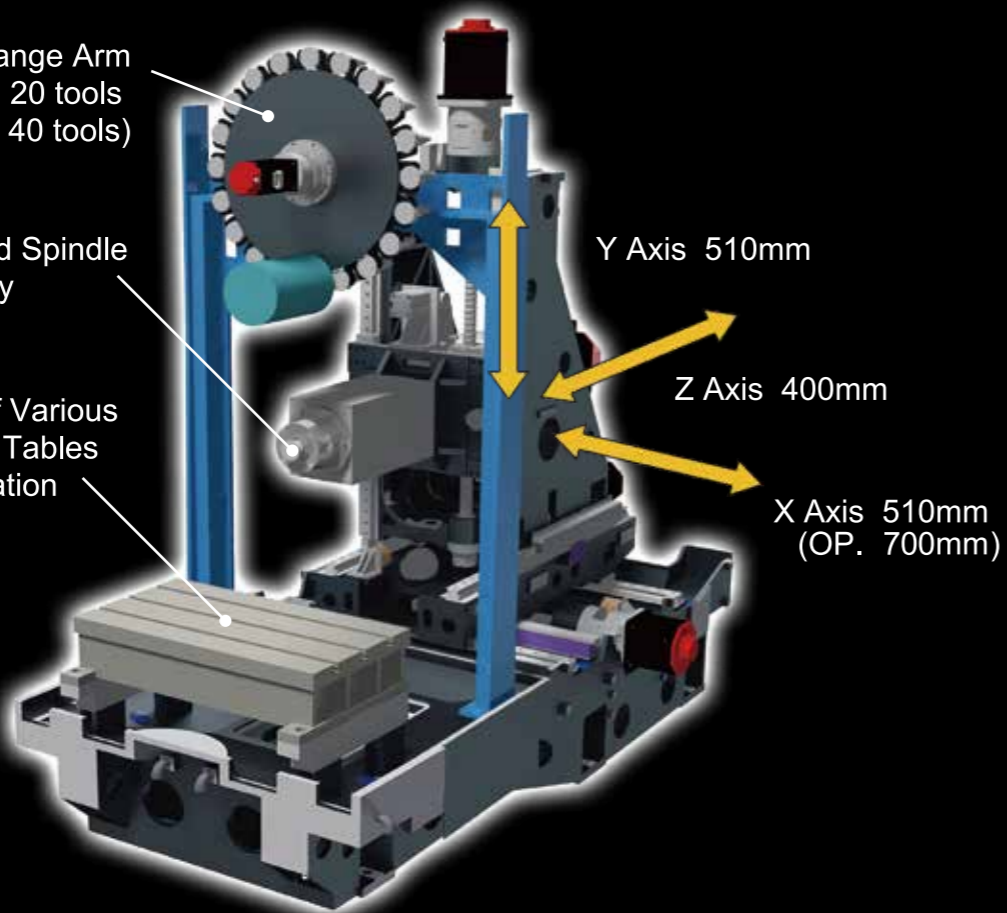

High Reliability

Trouble-free design

Armless ATC (20-/40-tool system)

Tool change does not rely on a tool change arm. Instead, the spindle directly changes tools with the magazine.

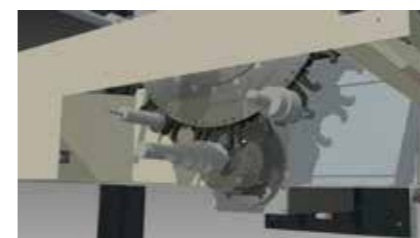

Isolation of Machining Area from Mechanism

By separating the machining area from the axis driving mechanism by the vertical slide covers, troubles of the driving components caused by coolant and chips are substantially reduced.



Smooth Chip Disposal

Thanks to the column moving structure, the volume of the machining area is minimized. Combined with the large opening in the bed, very efficient chip disposal is possible.

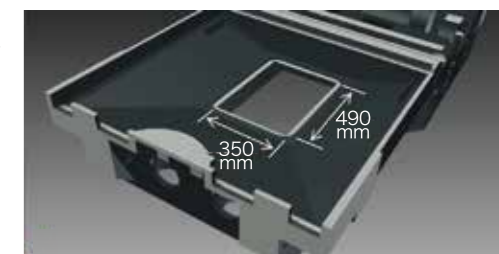

User-Friendliness

Adaptable to a Variety of Applications

Because of the fixed table structure, piping arrangement for automatic clamping fixtures is easy, and the mounting height of work pieces is freely adjustable depending on customers' requirements. It is also possible to install various types of rotary tables.



Space Saving / Energy Saving

The compact body is the most suitable for machining lines. The standard machine has no hydraulic unit, contributing to power saving.



High Rigidity Easily cuts ferrous materials

Rigid Spindle with Power

The Z-axis moves with back and forth movements of the column. That assures higher rigidity of the spindle than quill type spindles. The spindle unit has 6 bearings for better stability.

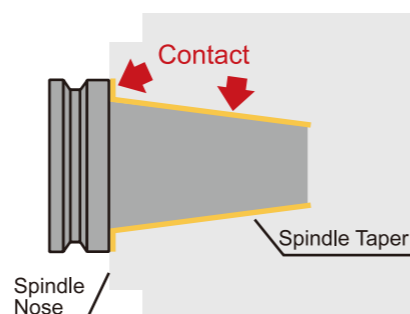
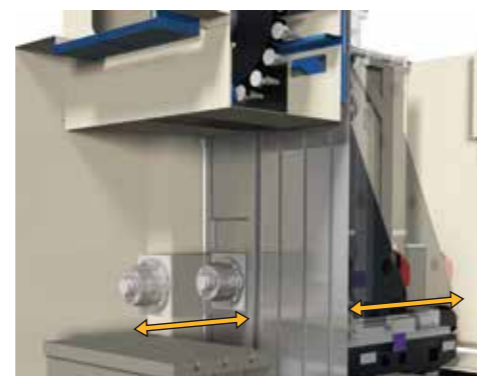
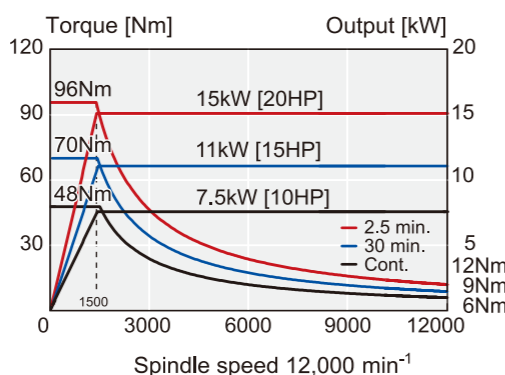
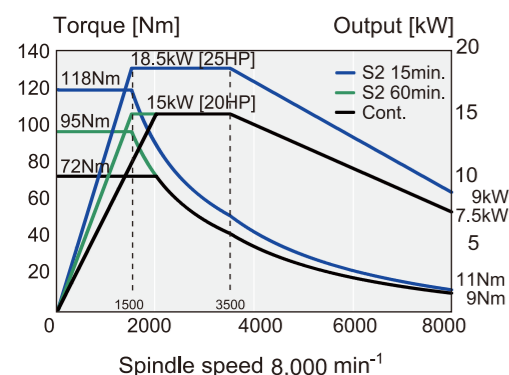

Double Contact
The spindle is designed to accept double contact tool holders.

Flexibility in Material Handling

By construction of wide-ranging peripheral equipment such as robots and gantry loaders, automated machining can be realized.

