

KIWA Japan

Triple V22

Column Traverse Type Vertical Machining Center



- Stroke (X/Y/Z) 610/410/510 mm
- Pallet size 820x410 mm : 2APC
820x450 mm : Single pallet
- Rapid feed (X/Y/Z) 60,000 mm/min⁻¹
- Spindle taper 7/24 Taper NT No. 40
- Spindle speed 10,000 min⁻¹ (Opt. 12,000 min⁻¹)
- Number of tools 24 (Opt. 30)

● **Spindle**

Cutting fluid flows inside the spindle head to minimize its thermal expansion.

NEW



ATC

The High-Speed ATC System is essential to minimize non-cutting time.

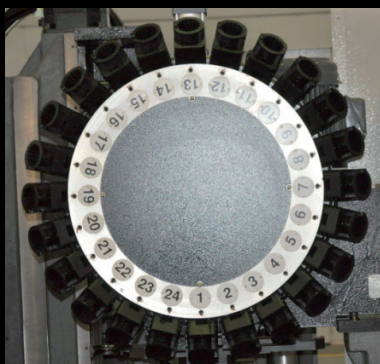

2APC APC Time: 5.5 sec.
(4.0 sec. w/o axes movements)



KIWA MACHINERY CO., LTD.

Triple V22 Standard Features

	Triple V22-S	Triple V22-R		Triple V22-S	Triple V22-R
● TRAVEL			● APC		
X/Y/Z axis	610/410/510 mm [24.0"/16.1"/20.1"]		Number of pallets	2 pallets	
Spindle center to column	440 mm [17.3"]		Pallet change system	Rotation	
Spindle nose to table top Table top height (from the floor)	150 to 660 mm [5.9" to 26.0"] 925 mm [36.4"]		APC time	5.5 sec. (4.0 sec. w/o axes movements)	
● TABLE / PALLET			● SPINDLE		
Size	820x450 mm [32.3"x17.7"]	820x410 mm [32.3"x16.1"] x 2	Spindle speed	10,000 min ⁻¹ (Opt.12,000 min ⁻¹)	
Max. load	600 kgs [1320 lbs]	500 kgs [1100 lbs] x 2	Spindle motor	11/7.5 kW [15/10 HP]	
Configuration	Three 18mm T slots w/125mm pitch	45-M16 P80	Spindle max. torque	56 Nm for 10,000 min ⁻¹	
Max. work piece height	600 mm [23.6"]		Spindle taper	ISO 7/24 Taper NT No. 40	
● ATC			Lubrication	Grease (packed)	
Type of tool shank	MAS BT40/CAT40		Spindle clamping force	12000 N	
Number of tools	24 (Opt. 30)		● FEED		
Type of pull-stud	JIS		Rapid feed (X/Y/Z)	60000 mm/min [2360 ipm]	
Max. tool diameter (Adjacent pots full/empty)	Dia. 90/160 mm [3.5"/6.3"] (for 24ATC)		Cutting feed (X/Y/Z)	30000 mm/min [1180 ipm]	
Max. tool length	245 mm [9.6"]		● SUPPLY / TANK		
Max. tool weight	7 kgs [15.4 lbs]		Electric voltage	AC 200V	
Tool selection system	Random memory		Electric power supply	30 KVA	
Tool to tool / Chip to chip	1.3 / 4.0 sec.		Air pressure	0.4 MPa	
● MOTOR			Hydraulic unit tank	20 liters	
Feed axis motor (X/Y/Z)	3.0/3.0/3.0 kW [4.0/4.0/4.0 HP]		Coolant tank	420 liters	
Grease pump motor	24 W [0.032 HP]		Grease cartridge	0.7 liters	
Coolant pumps	400 W [0.5 HP] x 1 / 600 W [0.8 HP] x 1		● SIZE		
Hydraulic pump	2.2 kW [2.9 HP]		Machine height	2960 mm [116.5"]	
			Floor space	2015x2640 mm [79.3"x103.9"]	2015x3155 mm [79.3"x124.2"]
			Machine weight	6200 kgs [13640 lbs]	8200 kgs [18040 lbs]

MACHINE SIZE

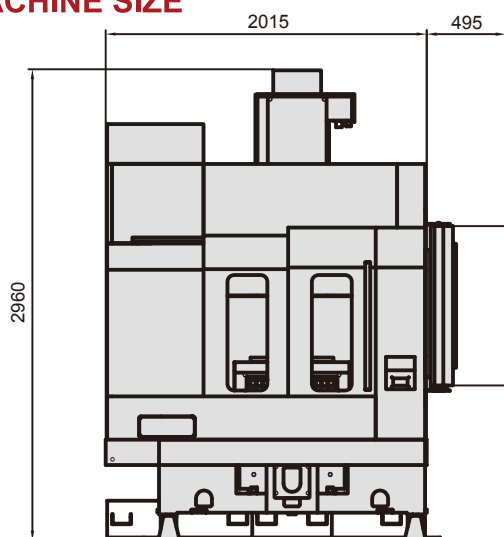

【Front View】

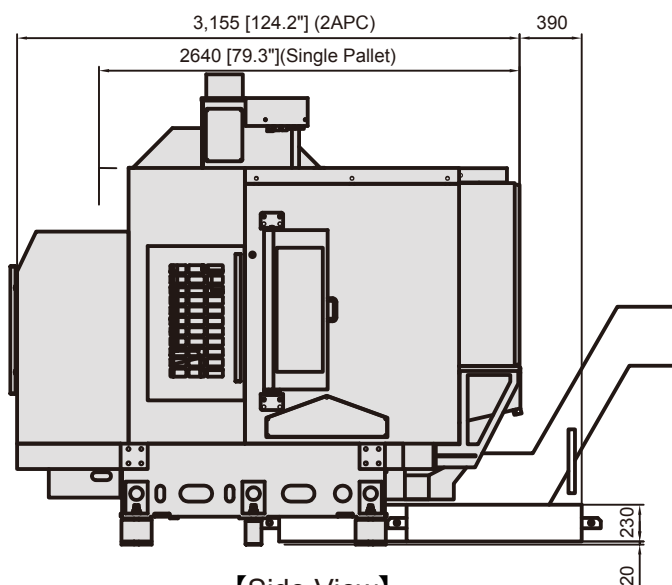

【Side View】

Specifications and dimensions are subject to change without notice.

KIWA MACHINERY CO., LTD.
 522-51 Harade Kuramochi-cho,
 Nabari, MIE 518-0752, JAPAN
 TEL : 0595-64-4758 FAX : 0595-64-7529
 WEB : <http://www.kiwa-mc.co.jp/en/>
 E-mail : overseas@kiwa-mc.co.jp